

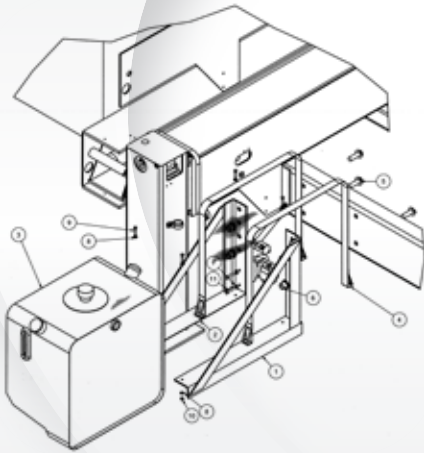

Boom Truck

Quantified Results:

- 27% cost savings
- 57% smaller in size
- 61% reduction in entrained air
- 50% reduction in part numbers



Former State

35 Gallon Hydraulic Reservoir

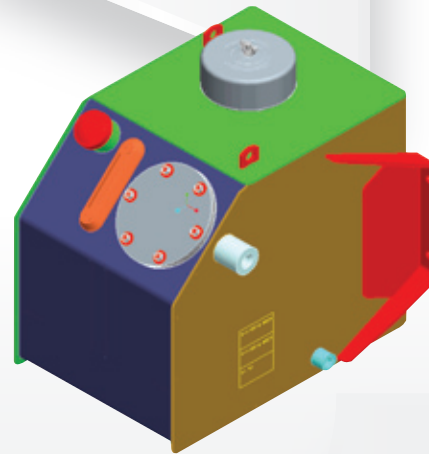

Current State

18 Gallon Hydraulic Reservoir

Challenge:

- Based on availability, customer was intending on using a reservoir much larger than hydraulic system requirements.

Solution:

- Utilizing HydroNucleation™ technology to commonize two platform requirements into one common fluid conditioning device.

